

Modelling and Simulation of BLDC Motor Using State Space Approach

C. Mohankrishna¹, N. Rajesh Kumar Gowd², A. Ramesh³, G. Subba Rao Gupta⁴

Assistant Prof, Dept. of EEE, Sri Venkateshwara Institute of Technology Engg College, Ananthapuramu, A.P, India^{1,3}

Lecturer, Dept of EEE, Sri Krishnadevaraya university College of Engg & Technology, Ananthapuramu, A.P, India²

Assistant Prof, Dept. of EEE, Anantha lakshimi Institute of Technology & science, Ananthapuramu, A.P, India⁴

Abstract: Brushless Direct Current (BLDC) motors are one of the motor types rapidly gaining popularity. BLDC motors are used in industries such as Appliances, Automotive, Aerospace, Consumer, Medical, Industrial Automation Equipment and Instrumentation. As the name implies, BLDC motors do not use brushes for commutation instead, they are electronically commutated. BLDC motors have many advantages over brushed DC motors and induction motors. A few of these are: Better speed versus torque characteristics, High dynamic response, High efficiency, Long operating life, Noiseless operation, Higher speed ranges. Brushless DC (BLDC) motor simulation can be simply implemented with the required control scheme using specialized simulink built-in tools and block sets such as simpower systems toolbox. But it requires powerful processor requirements, large random access memory and long simulation time. To overcome these drawbacks this paper presents a state space modeling, simulation and control of permanent magnet brushless DC motor. By reading the instantaneous position of the rotor as an output, different variables of the motor can be controlled without the need of any external sensors or position detection techniques. Simulink is utilized with the assistance of MATLAB/Simulink to give a very flexible and reliable simulation. With state space model representation, the motor performance can be analyzed for variation of motor parameters.

Keywords: BLDC, Electronic Commutation, MATLAB/Simulink.

I. INTRODUCTION

With rapid developments in power electronics, power semiconductor technologies, modern control theory for motors and manufacturing technology for high performance magnetic materials, the brushless DC motors (BLDCM) have been widely used in many fields. Due to the advancement of small size, good performance, simple structure, high reliability and large output torque, BLDC motors have attracted increasing attention. However, the application of position sensor makes the motor body heavy, as well as lots of wires are needed, which in turn brings complication and interference in the design.

Thus the position sensor less control technology attracts increasing research interest and currently becomes one of the most promising trends of BLDCM control system. The modeling and simulation analysis for BLDCM depends on computer engineering and can effectively shorten development cycle of position sensor less BLDCM control system and evaluate rationality of the control algorithm imposed on the system. This provides a good foundation for system design and verifies novel control strategy. MATLAB [1] possessing powerful scientific computing and graphics processing function is an interactive software system developed by Math works company for system simulation. In paper [2], BLDC motor has been designed based on transfer function model. Though the transfer function model provides us with simple and powerful analysis and design techniques, it suffers from certain drawbacks such as transfer function is only defined under zero initial conditions. Further it has certain limitations due to the fact that the transfer function model is only

applicable to linear tie-invariant systems and there too it is generally restricted to single input single output systems.

Another limitation of the transfer technique is that it reveals only the system output for a given input and provides no information regarding the internal state of the system. In this paper, the motor is designed based on state space model to get information about the state of the system variables at some predetermined points along the flow of signals. By adopting this model, powerful processor requirement, large random access memory can be avoided with more design flexibility and faster results can be obtained.

2. STATE SPACE MODELING

2.1. Assumptions

- 1) The motor's stator is a star wound type
- 2) The motor's three phase are symmetric, including their resistance, inductance and mutual inductances [3].
- 3) There is no change in rotor reluctance with angle due to non-salient rotor.
- 4) There is no misalignment between each magnet and the corresponding stator winding.

2.2. Modeling Brushless DC Motor

The coupled circuit equations [4] of the stator winding in terms of motor electrical constants are

$$\begin{bmatrix} V_{as} - V_n \\ V_{bs} - V_n \\ V_{cs} - V_n \end{bmatrix} = \begin{bmatrix} R_s & 0 & 0 \\ 0 & R_s & 0 \\ 0 & 0 & R_s \end{bmatrix} \begin{bmatrix} I_a \\ I_b \\ I_c \end{bmatrix} + P \begin{bmatrix} L_{aa} & L_{ab} & L_{ac} \\ L_{ba} & L_{bb} & L_{bc} \\ L_{ca} & L_{cb} & L_{cc} \end{bmatrix} \begin{bmatrix} I_a \\ I_b \\ I_c \end{bmatrix} + \begin{bmatrix} E_a \\ E_b \\ E_c \end{bmatrix} \quad (1)$$

where R_s is the stator resistance per phase, I_a I_b I_c are the

stator phase currents, p is the time derivative operator, E_a , E_b , E_c are the back emfs in the respective phases in (1), V_n is the neutral point node voltage given by

$$V_n = \frac{1}{3}(V_{as} + V_{bs} + V_{cs}) - \sum BEMFs \quad (2)$$

\sum BEMFs means summing up the individual phase emfs on an instant-to-instant basis.

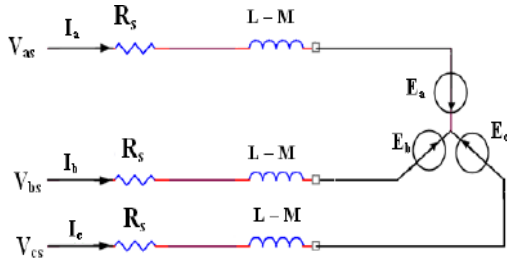

Fig. 1. Equivalent circuit for stator windings

The induced emfs are all assumed to be trapezoidal, whose peak value is given by:

$$E_p = (BLv)N = N(Blr\omega) = N\Phi\omega = \lambda\omega \quad (3)$$

Where:

B is the flux density of the field in Weber

L is the rotor length

N is the number of turns per phase

ω is the electrical angular speed in rad/sec

Φ represents flux linkage= BLr

λ represents the total flux linkage given as the product number of conductors and flux linkage/conductor. If there is no change in rotor reluctance with angle because of non-salient rotor and assuming three symmetric phases, inductances and mutual inductances are assumed to be symmetric for all phases, i.e. (1) becomes:

$$\begin{bmatrix} V_a \\ V_b \\ V_c \end{bmatrix} = R_s * \begin{bmatrix} 1 & 0 & 0 \\ 0 & 1 & 0 \\ 0 & 0 & 1 \end{bmatrix} \begin{bmatrix} I_a \\ I_b \\ I_c \end{bmatrix} + p \begin{bmatrix} L & M & M \\ M & L & M \\ M & M & L \end{bmatrix} \begin{bmatrix} I_a \\ I_b \\ I_c \end{bmatrix} + \begin{bmatrix} E_a \\ E_b \\ E_c \end{bmatrix} \quad (4)$$

Simplifying (3) further we get equation (4)

$$\begin{bmatrix} V_{as} \\ V_{bs} \\ V_{cs} \end{bmatrix} = R_s * \begin{bmatrix} 1 & 0 & 0 \\ 0 & 1 & 0 \\ 0 & 0 & 1 \end{bmatrix} \begin{bmatrix} I_a \\ I_b \\ I_c \end{bmatrix} + p \begin{bmatrix} L-M & 0 & 0 \\ 0 & L-M & 0 \\ 0 & 0 & L-M \end{bmatrix} \begin{bmatrix} I_a \\ I_b \\ I_c \end{bmatrix} + \begin{bmatrix} E_a \\ E_b \\ E_c \end{bmatrix} \quad (5)$$

The generated electromagnetic torque is given by

$$T_e = [E_a I_a + E_b I_b + E_c I_c] / \omega \text{ (in N.m)} \quad (6)$$

The induced emfs can be written as

$$\begin{aligned} E_a &= f_a(\theta) \lambda \omega \\ E_b &= f_b(\theta) \lambda \omega \\ E_c &= f_c(\theta) \lambda \omega \end{aligned} \quad (7)$$

Where $f_a(\theta)$, $f_b(\theta)$ and $f_c(\theta)$ are functions having same shapes as back emfs with maximum magnitude of ± 1 . These values from (6) can be substituted in (5) to obtain the value of torque.

Also

$$J(d\omega/dt) + B\omega = T_e - T_l \quad (8)$$

Where

T_l : load torque

J: moment of inertia

B: friction coefficient.

Electrical rotor speed and position are related by

$$d\theta/dt = (P/2) * \omega \quad (9)$$

Where P is the number of poles in the motor.

Combining all the equations, the system space form becomes

$$X' = Ax + Bu \quad (10)$$

Where

$$x = [I_a \ I_b \ I_c \ \omega \ \theta]^T \quad (11)$$

Thus the state space matrix becomes:

$$A = \begin{bmatrix} -R_s/L_1 & 0 & 0 & (\lambda p^* f_a(\theta))/L_1 & 0 \\ 0 & -R_s/L_1 & 0 & (\lambda p^* f_b(\theta))/L_1 & 0 \\ 0 & 0 & -R_s/L_1 & (\lambda p^* f_c(\theta))/L_1 & 0 \\ (\lambda p^* f_a(\theta))/J & (\lambda p^* f_b(\theta))/J & (\lambda p^* f_c(\theta))/J & -B/J & 0 \\ 0 & 0 & 0 & P/2 & 0 \end{bmatrix} \quad (12)$$

$$B = \begin{bmatrix} 1/L_1 & 0 & 0 & 0 \\ 0 & 1/L_1 & 0 & 0 \\ 0 & 0 & 1/L_1 & 0 \\ 0 & 0 & 0 & -1/J \\ 0 & 0 & 0 & 0 \end{bmatrix} \quad (13)$$

And

$$U = [V_a \ V_b \ V_c \ T_l]^T \quad (14)$$

Where:

L_1 : L-M; L: self inductance of the winding per phase, M: The mutual inductance per phase

$V_a \ V_b \ V_c$, are the per phase impressed voltages on the motor windings.

All the equations form the entire state space model for the BLDC. Consistent system of units must be used.

2.2 Block Diagram of BLDC Motor:

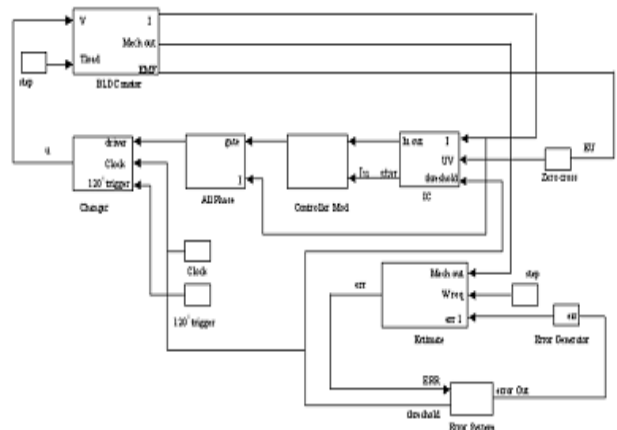

Block Diagram of BLDC Motor

3. Simulation Blocks and Operation

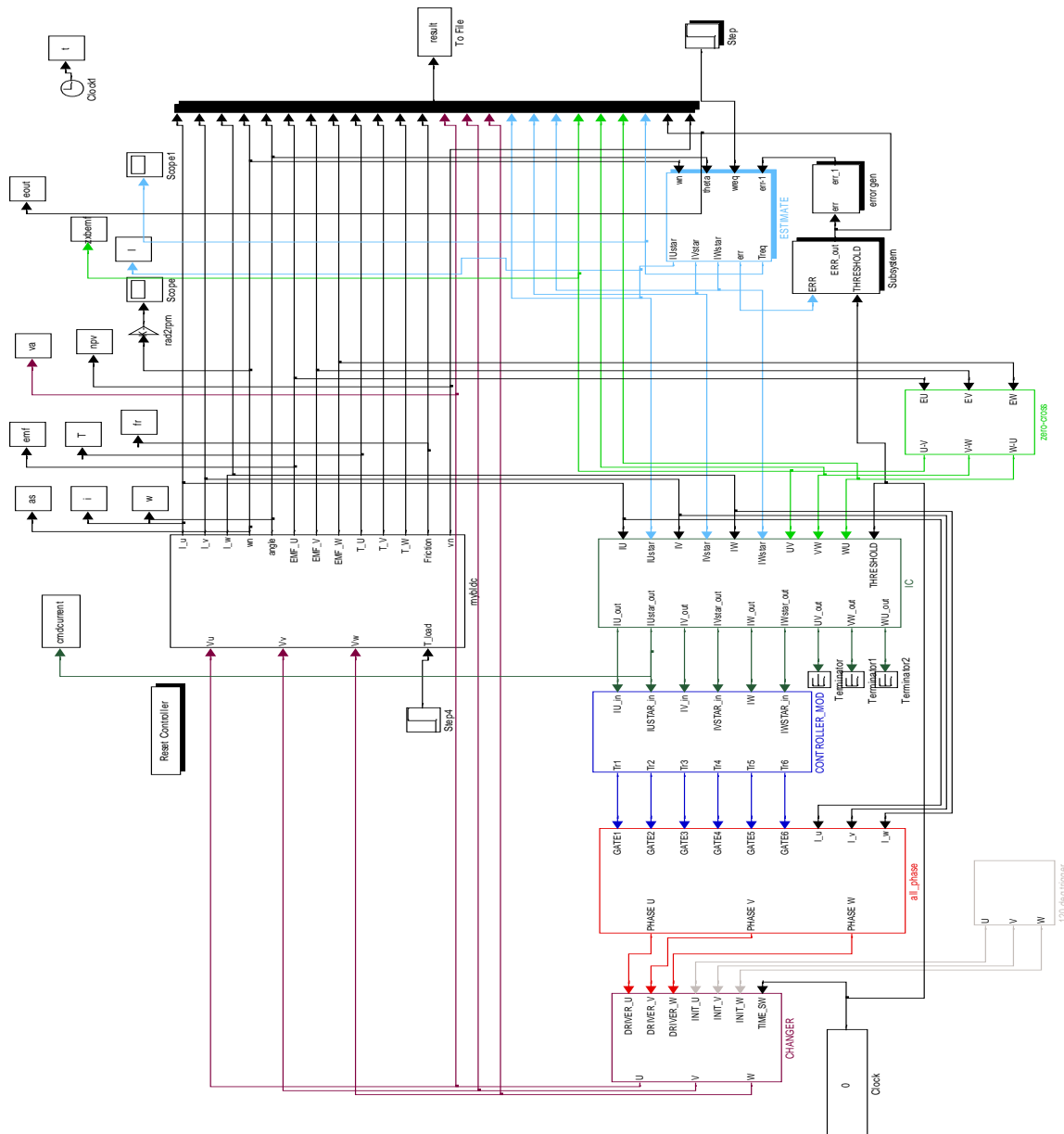

Fig 2. Simulink model of BLDC motor

The simulation has five main blocks. They are BLDC motor, controller block, inverter block, estimate block and changer block shown in Fig. 2. Each main block has several sub-blocks. Some blocks are logical and some are made using S-Function. The BLDC motor block contains state space sub-block where matrices A, B, C, D are located with the provision that the initial condition can be varied. In the S-Function, coding file is linked and is shown in Fig. 3. The sequences of operation of the above blocks are described by the flowchart shown Fig. 4. The simulation starts with a starter block (No. 1 in chart) that generates 3Φ input voltage to the system's core block (No.2 in chart) for one cycle. A changer block is used to close the control loop after the random ramping of the motor. Once the loop is closed, the starter block will be disconnected from the system and the motor will start receiving the phase voltages from the connected controller through inverter.

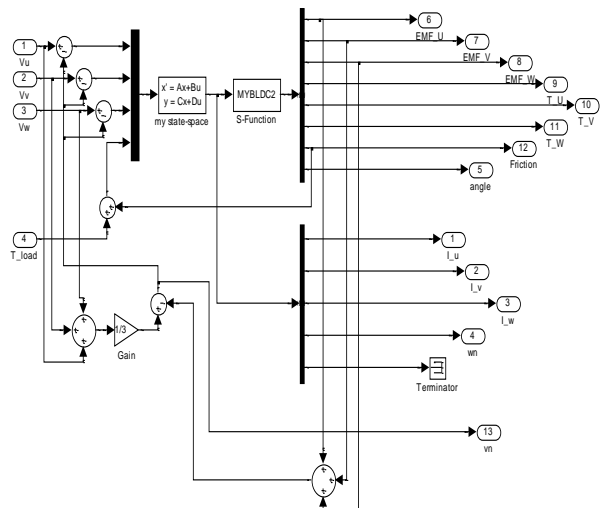

Fig 3. Inside the core block in BLDC motor block

The PID controller is tuned by Ziegler Nichols method. By this method, the values of $K_p=16.61$, $K_i=0.0134$ and $K_d=0$ are chosen. An S-Function block is connected to the state space block to choose the motor specifications such as, the number of conductor turns per phase, resistance per phase, rotor dimensions etc as defined by the user. The S-Function will read the instantaneous position among twelve positions which are separated by 30° . Depending on the position [6], the back e.m.f and torque in each phase will be defined. The estimate block contains the PID controller. The block again is an M-file S-Function. This block calculates the reference phase current from the speed and required torque. Required torque is calculated by actual speed and the speed error value. The above value will be read and used in a PID controller [7]. The required torque is calculated as follows

$$T_{req} = \left[E \times \left(K_p + (K_i \times 0.5 \times t_s) + \frac{K_d}{t_s} \right) \right] + \left[E_{-1} \times \left(0.5 \times t_s \times K_i - \frac{K_d}{t_s} \right) \right] \quad (15)$$

where E is the angular speed error, E-1 is the previous time step error in angular speed, t_s is the sampling time, K_p , K_i , K_d are proportional, integral and derivative constants.

The required current is calculated from the instantaneous required torque. Then it is converted by means of an approximated Park's Transformation to three phase currents. The approximated park's transformation gives the corresponding phase current to every stator phase according to the rotor's position. A hold block (No.3 in chart) is used to hold on both the required and instantaneous current values in the open loop. Once the changer block closes the control loop, the hold block will give an access to the current values to pass to the present controller scheme.

In this simulation, hysteresis controller function is chosen. Usually, the controller is used to fire the gates of six step inverter switches, as in [8].

4. SIMULATION RESULTS AND DISCUSSION

The motor specifications used in this simulation are shown in Table. 1. The simulation was run for 0.13seconds (simulation time). When the reference speed equals 4000 rpm, the simulation curves of current, back emf, rotor position, and torque and is shown in Fig. 2,3,4,5. Load torque is applied at 0.01 seconds. The motor speed stabilizes in 0.058 seconds with 0% overshoot. From Fig. 4, the back emf is almost trapezoidal with 120° phase difference. Since the three phase torques are calculated from 3Φ currents, it gives 120° phase difference between each phases as shown in Fig. 5. From Fig. 3, the rotor position can be analyzed under various aligned and unaligned conditions.

1. Angular speed

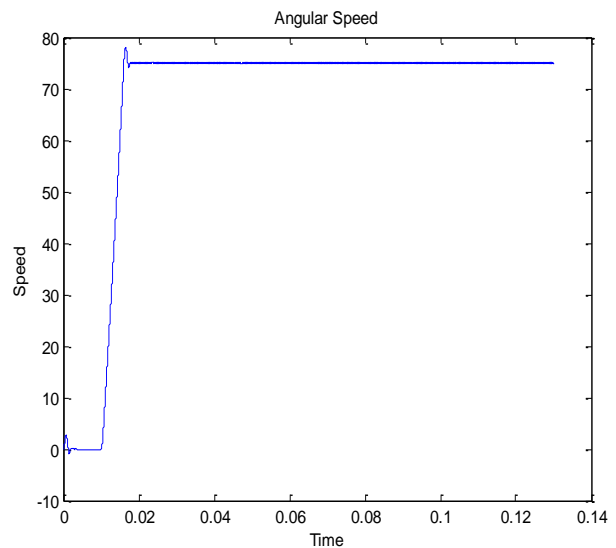

Fig: 1

2. Current

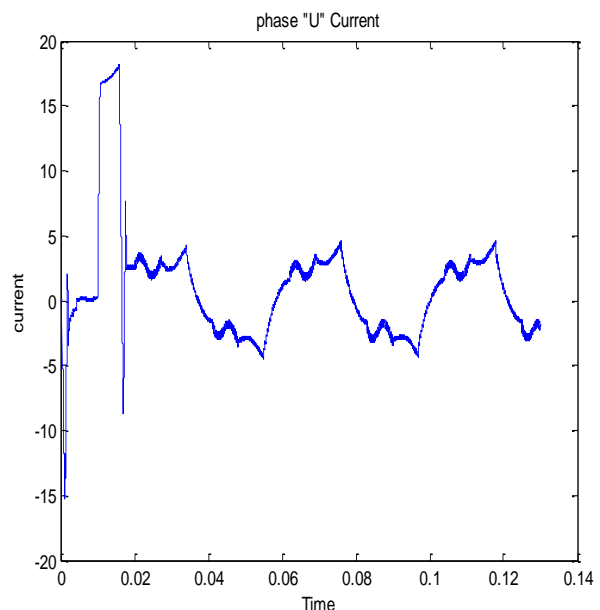

Fig: 2

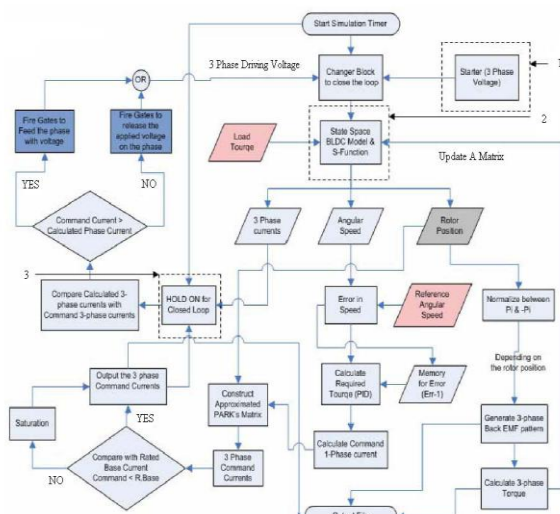

Fig. 4. Detailed flow chart for the whole control process

However, each firing scheme determines certain voltage in each phase in the stator. According to the change in the firing angle, stator voltage received by the inverter block changes and the rotor speed is varied.

3 .Rotor position

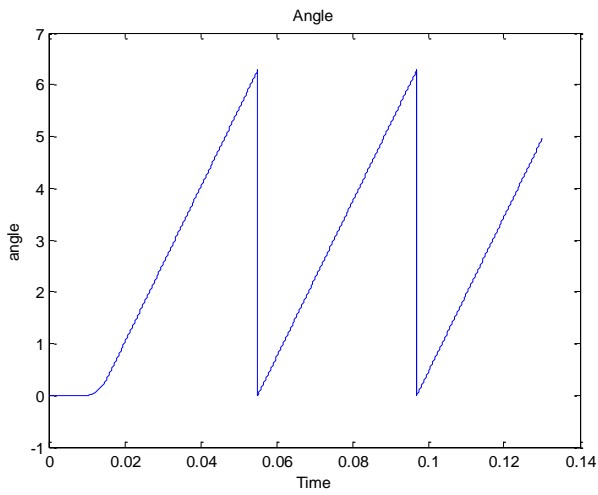

Fig: 3

6 Friction:

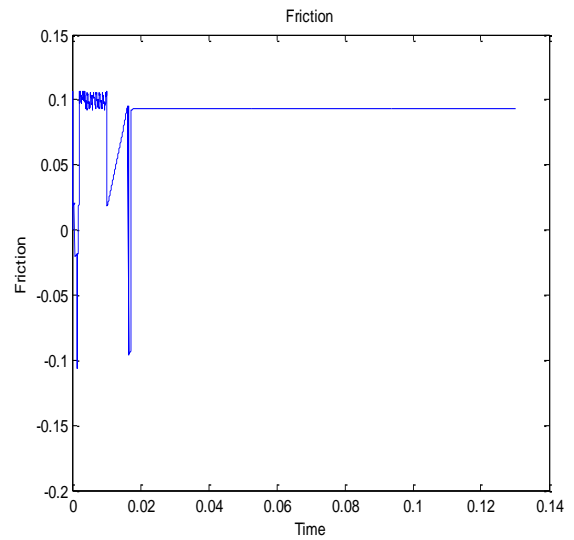

Fig: 6

4. EMF of Phase A:

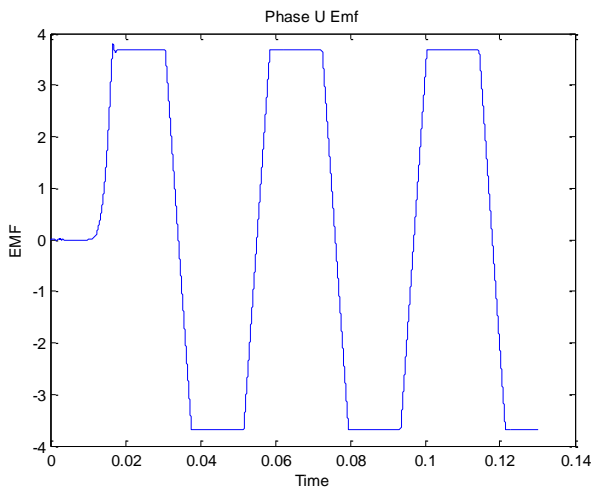

Fig: 4

7. Error Out:

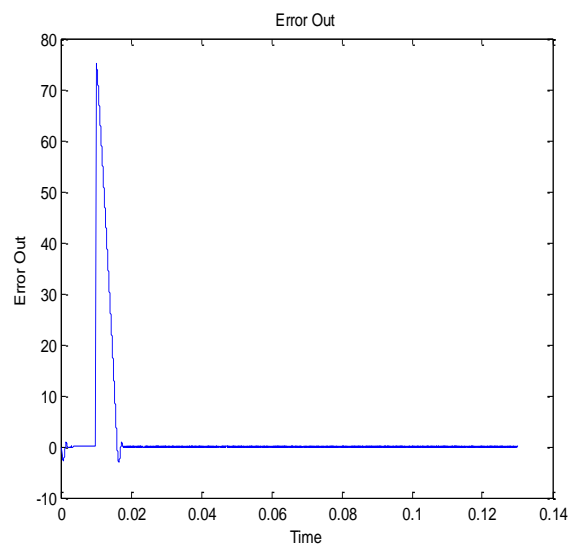

Fig: 7

5. Torque

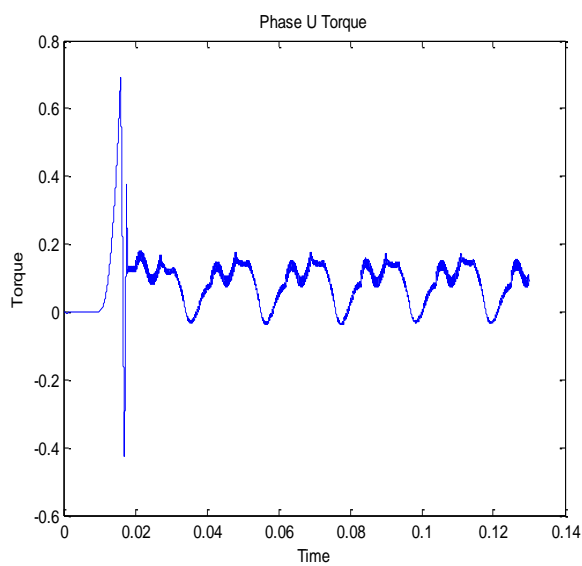

Fig: 5

8 Neutral point Voltage:

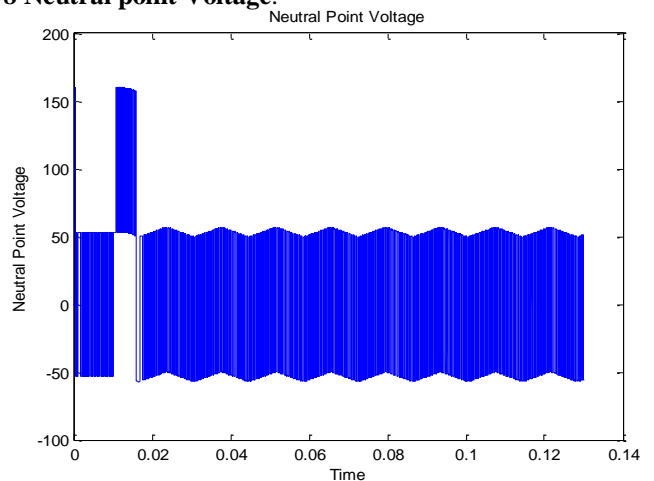

Fig: 8

Table 1 BLDC motor specification

Current	34 A	Rotor length	30 cm
Torque	0.9 N.m	Rotor radius	20 cm
Self inductance per winding	2.72 mH	No. of turns per phase	100
Mutual inductance between windings	-1.5 mH	Flux density	0.8167 wb
Motor inertia	0.0002	Coulomb friction	0.0178 N
Rated speed	4500 RPM	Static friction	0.089 N
Number of poles	4	Viscous friction	0.002 N
Number of phases	3	Input dc voltage	160 V
Winding resistance per phase	0.7 Ω	No. of slots per pole per phase	100

5. CONCLUSIONS

BLDC motor analysis based on state space model can be easily carried out using MATLAB 7.1 version. This model has many advantages over transfer function model. The simulation study using state space model has been validated.

Further using state space model, the performance characteristics of the BLDC motor can be evaluated for different machine parameters, which can be easily varied in the simulation study and useful information can be obtained. The simulation results demonstrate that the simulated waveforms fit theoretical analysis well. However, the simulation involves solving many simultaneous differential equations and the results obtained are highly dependent upon the choice of the system solver, where some solver gives highly accurate results, but need longer time to terminate. Through the modularization design, a lot of time spent on design can be saved and the design efficiency can be promoted rapidly. The method proposed in this paper provides a novel and effective tool for analyzing and designing the control system of brushless DC motor.

REFERENCES

- [1] MATLAB 7.3 (2006), The Mathworks Inc.
- [2] Navidi, N.; Bavafa, M.; Hesami, S. (2009): A new approach for designing of PID controller for a linear brushless DC motor with using ant colony search algorithm. IEEE Power & Energy Engineering conference, pp. 1-5.
- [3] Figueroa, J.; Brocart, C.; Cros, J.; Viarouge, P. (2003): Simplified methods for ployphase brushless DC motors. Mathematics and Computer in Simulation, 63 (3-5), pp. 209-224.
- [4] Duane, C. Hanselman. (1994): Brushless permanent-magnet motor design. New York, McGraw-Hill.
- [5] Krishnan, R. (2007): Electric motor drives-modeling, analysis and control. Pearson prentice Hall, India.
- [6] Dixon, J. W.; Rodriguez, M.; Huerta, R. (2002): Position estimator and simplified current control strategy for brushless DC motor using DSP technology. IEEE Industrial Electronics Conference, IECON'02, pp. 5-8.
- [7] Palani, S. (2010): Contol system engineering. Second edition, McGraw Hill, India.
- [8] Somanatham, R.; Prasad, P. V. N.; Rajkumar, A. D. (2006): Modeling and simulation of sensor less control of PMBLDC motor using zero-crossing back EMF detection. IEEE International Symposium on Power Electronics, Electric Drives, Automation and Motion,

BIOGRAPHIES



C. Mohan Krishna M.Tech working as Assistant Professor in Sri Venkateshwara Institute of Technology Engineering College Anantapuramu. His areas of interest include Power Electronics.



N. Rajesh Kumar Gowd has graduated his B.Tech from st.john's College of Engg & Tech, Kurnool, A.P, India and M.Tech from Bharath institute of Engineering and Technology-Ibrahimpatnam, Hyderabad, T.S, India. Presently he is working as Lecturer in

Dept of EEE in Sri Krishnadevaraya University college of Engineering and Technology, Ananthapuramu,A.P,India. He has published 5 International Journals .His research areas of interest are Electrical Power System, Reliability, Power electronics design.



A. Ramesh. has graduated B.TECH from MITS, MADANAPALLI (2006-2010),affiliated J.N.T University, Anantapuramu, A.P, India..He received M.Tech degree from SVCET, CHITTOR (2010-2012). He is presently working as Assistant Professor in the Department of

Electrical and Electronics Engineering, SVIT Engineering College, Anantapuramu, A.P, India. His areas of interest in Power Electronics, Electrical Drives, Power systems.



G. subbarao Gupta has graduated his B.Tech from st.Mary's College of Engg.& Tech, Hyderabad, T.S, India and M.Tech from st. Mary's College of Engg.& Tech, Hyderabad,T.S,India. Presently he is working as Assistant Professor in Dept. of EEE in Anantha

Lakshmi college of science and technology, affiliated jntu-ananthapuramu, A.P, India. His research areas of interest are Electrical Power System, control systems.